

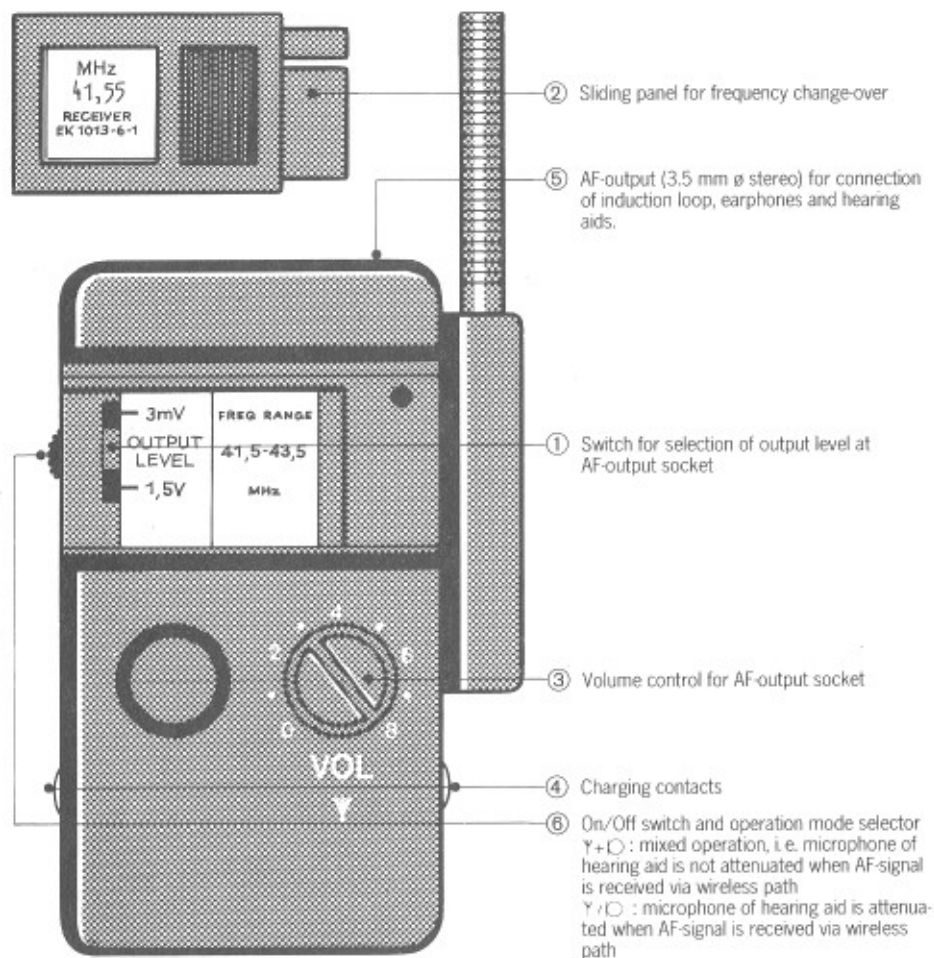

User's Guide

Receiver EK 1013 - 6 - 1

Controls



Potentiometer for adjustment of attenuation

Inserting batteries

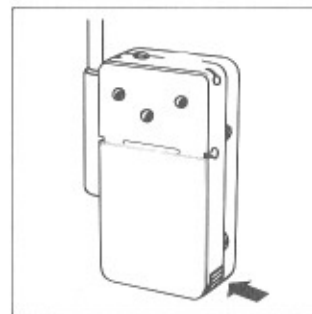

Figure 1: Opening the battery compartment

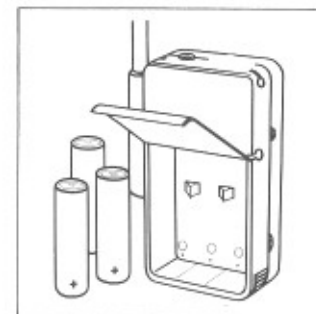

Figure 2: Inserting batteries

Adjustment of attenuation

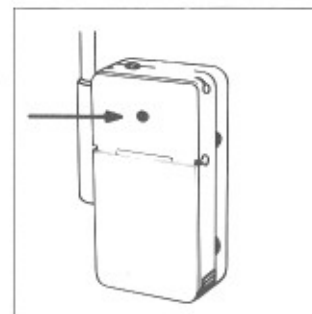

Figure 3

Removing the sliding panel

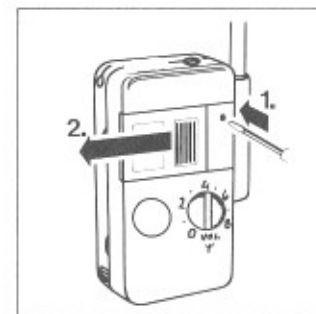

Figure 4

Fastening chest and neck strap

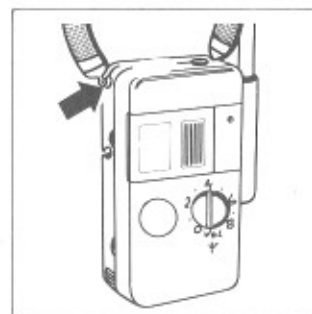

Figure 5

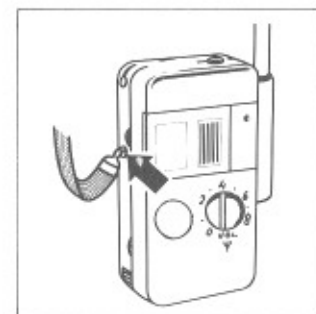

Figure 6

Note: During operation avoid pressing the antenna of the EK 1013 - 6 - 1 against your body or touching it with your hand as this would affect the performance of the receiver.

RF-Receiver EK 1013-6-1

Delivery includes: 1 receiver
1 chest strap EZU 1011
1 neck strap EZU 1011-1

Introduction

The EK 1013-6-1 is a one-channel, battery operated RF-receiver, used for wireless transmission in connection with a Mikroport transmitter SK 1013-6-1.

The design and circuitry of the unit are primarily intended for people with hearing difficulties, who are looking for a technical aid which would enable them to keep in touch even during difficult acoustic conditions. One typical application is acoustic support for such people when they attend schools, evening classes or university. Using a Sennheiser Mikroport system consisting of EK 1013-6-1 and SK 1013-6-1, a person with impaired hearing will no longer depend on a signal distorted by a noisy environment and weakened by the distance, but will receive the spoken word directly, i. e. with the room acoustics and the environmental noise eliminated.

The EK 1013-6-1 has a single-channel design. A label on the front of the device shows which frequency is in use. Hearing aids, headphones, stethoscope type earphones, induction plates or the EZT 1011 induction loop can be connected to the receiver output. The output voltage (volume) is adjustable.

The "HiDyn" noise and interference suppression system and a built-in squelch guarantee highest possible transmission quality.

The EK 1013-6-1 may be powered by three Mignon batteries, type IEC LR 6, or by rechargeable NiCd-batteries of the same type.

Connection of a hearing aid with audio input

One or two hearing aids fitted with an audio input can be connected to socket (5).



Wiring of AF-output

After connecting the hearing aid put mode selector switch (6) in position $\Upsilon + \text{D}$ or Υ / D and switch (1) in position "3 mV":

$\Upsilon + \text{D}$ In this operation mode the microphone signal of the hearing aid and the AF-signal delivered by the receiver are mixed.

Υ / D In this operating mode, the sensitivity of the built-in microphone in the hearing aid is reduced by a built-in automatic fading circuit when a modulated transmitter signal is received. In this way, information received from the transmitter will reach the ear distinctly and clearly. Whenever there is a break in the speaking, the microphone sensitivity returns to the value originally set. The volume of the receiver signal can be adjusted with control (3). The volume of the microphone signal depends on the setting at the hearing aid.

Since the attenuation depends on the input impedance of the hearing aid, an impedance matching is necessary. This matching is done with a potentiometer which is accessible through a hole in the rear housing shell (see fig. 3).

Adjustment

1. Connect hearing aid to EK 1013-6-1.
 - 1.1 Remove seal (fig. 3).
2. Put receiver and transmitter into operation. Make sure that transmitter and receiver operate on the same frequency.
3. Speak into the microphone of the transmitter.
4. Adjust volume of the signal coming from the receiver to volume of the hearing aid.
5. Speak into the microphone of the transmitter, while turning the potentiometer (7) at the EK 1013-6-1 so that the hearing aid's microphone sensitivity is audibly reduced.
6. Close hole at the rear housing shell with seal supplied.

Connection of a hearing aid without audio input

For hearing aids without audio input the signal can be coupled inductively to the hearing aid by using an induction loop or an induction plate. For this purpose switch (1) must be set to position "1.5 V".



Wiring of AF-output

For other applications headphones with an impedance of min. 47Ω can be connected to socket (5). The output voltage resp. volume can be adjusted with knob (3). The selected mode of operation has no influence on the function of the system. Switch (6) works only as On/Off switch and can be set to either position $\Upsilon + \text{D}$ or Υ / D .

Fitting the neck and chest strap

The unit comes with a neck strap and a chest strap for attachment to the body. Attach these two straps in the special slots as shown in figures 5 to 6. The straps must snap into place.

Please make sure that you neither squeeze the antenna against your body nor touch it with your hand when you use the unit. Also avoid winding the connecting cable to the hearing aid or headphones around the antenna. This would result on much poorer reception.

Battery/accu operation

To power the receiver, you can use non-rechargeable batteries, type Mignon IEC LR 6 or rechargeable NiCd batteries (1.2 V / 500 mAh). Alkaline manganese batteries are to be preferred, since the reliability of the receiver cannot be guaranteed if it is used with other types of dry cells. If the unit is used frequently it is more economical to use rechargeable NiCd batteries. For the purpose, the EK 1013-6-1 has two charging contacts on the side of the unit which make it possible to charge the batteries while they remain in the unit. The operating time depends on the battery type used:

NiCd rechargeable batteries: approx. 10 hours

Alkaline manganese batteries: approx. 30 hours.

For use with rechargeable batteries, please note:

1. Switch off the receiver before recharging.
2. Each time you have used the receiver, put it in the charging compartment of the recharger. This ensures that the batteries will always be fully charged.

Frequency change

A frequency change can be necessary, for instance, when two wireless systems within the same school use the same frequency and interfere with each other. To permit parallel operation of two or three systems within a school, the EK 1013-6-1 can operate on different frequencies. The sliding panel (2) contains the receiver component that determines the frequency. You can prepare the receiver for operation on another frequency by replacing the panel (fig. 4).

Technical data

Receiver

Receiving frequencies	one frequency can be selected by changing the sliding panel in a band of 2 MHz in the range of 30 to 45 MHz
Channel spacing	min. 40 kHz
Nominal swing	± 8 kHz
Sensitivity for 52 dB S/N	≤ 1.5 μ V
THD at 1 kHz and $V_{RF} = 1$ mW	≤ 3 %
Frequency response	40 Hz to 12 kHz
Noise suppression system	HiDyn
Electronic squelch (internally adjustable)	factory setting approx. 1 μ V

AF-output stage

Output level, switchable	max. 2 V / min. 6 mV
Internal resistance	approx. 1 Ω (level switch in position 1.5 V) approx. 1.5 M Ω (level switch in position 3 mV, mode selector switch in position $\Upsilon + \text{D}$) internally adjustable from 100 Ω to 2.3 k Ω (level switch in position 3 mV, mode selector switch in position Υ / D)
Minimum load impedance	50 Ω
Output socket	3.5 mm \varnothing jack

General data

Power supply	3 x Mignon (IEC LR 6) cells or NiCd accus 1.2 V
Current consumption	40 mA (4.5 V)
Operating time	approx. 30 hours with alkaline manganese batteries approx. 10 hours with NiCd accus
Dimensions in mm (without antenna)	100 x 66 x 37
Weight with batteries	approx. 180 g

We reserve the right to alter specifications, in particular with regard to technical improvements.

SENNHEISER ELECTRONIC KG
D-3002 WEDEMARK
TELEFON 051 30/583-0
TELEX 924623

Printed in Germany Publ. 6/86 33782